



SOCRATE

METERING  
BUSINESS UNIT



## SOCRATE—COMPANY OVERVIEW

For over 30 years, our focus is on the Italian and Mediterranean Oil and Gas Market offering Process Instrumentation Products, System and turnkey solutions for process analysis, Metering and Fire and Gas Safety Solutions.

Socrate provides to their valued customers the highest quality products & services, using engineering experience gained over many years of designing, implementing and commissioning hundreds of systems for numerous project applications.

Our multidisciplinary team is composed by qualified engineers and technicians with more than 20 years of mean experience in metering systems.

## SOCRATE – METERING BUSINESS UNIT

Design, manufacturing and commissioning of NATURAL GAS metering & measurement systems SKID-mounted.

### FISCAL OR CUSTODY METERING SYSTEM:

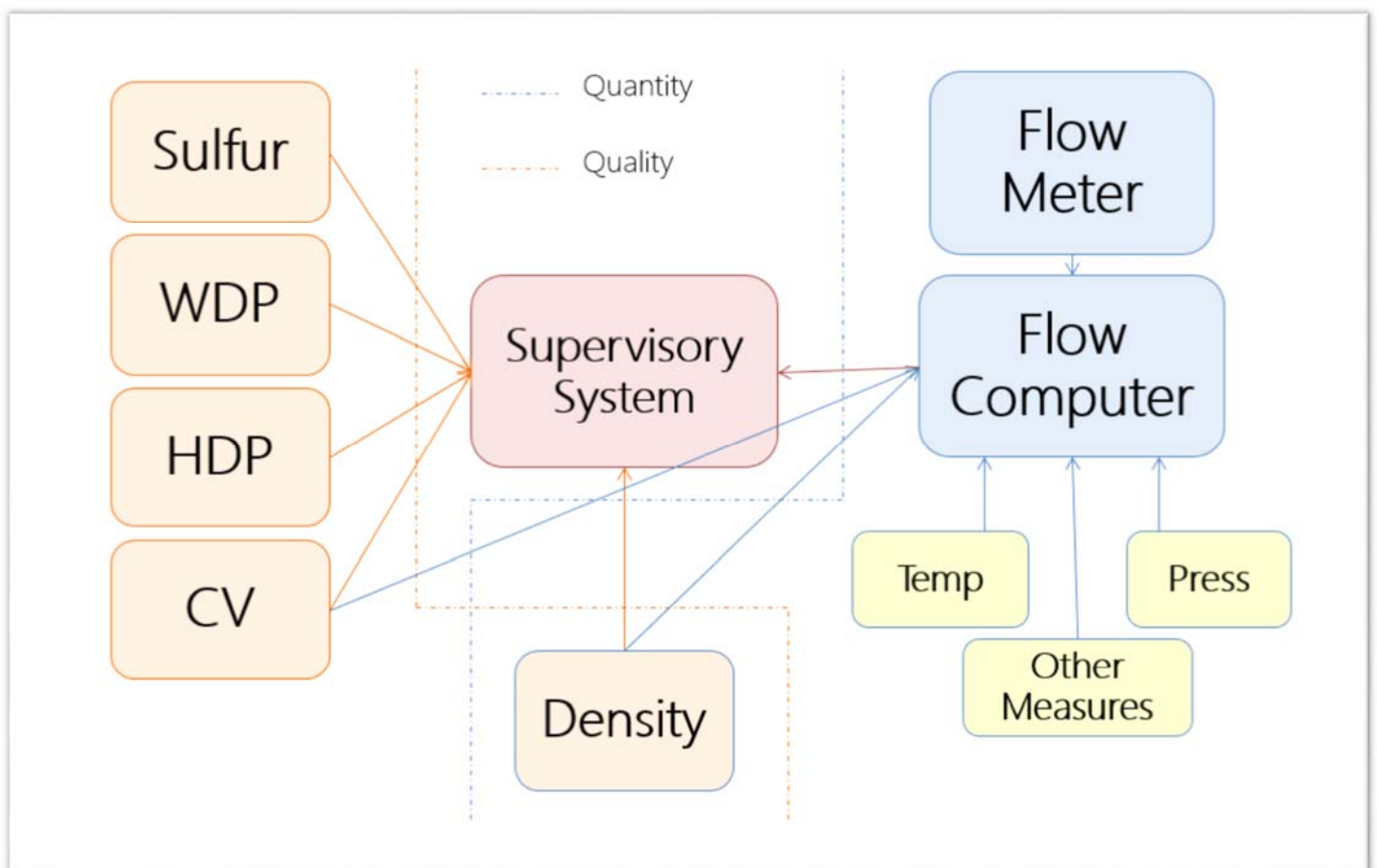



## SOCRATE – METERING BUSINESS UNIT

If you are measuring quantities of gas used or oil supplied, we provide the highest quality metering tools and systems to measure flow and usage:

- Fiscal Gas UFM
- Fiscal Gas Turbines
- Orifice Fittings
- Flow Computer
- Supervisory Systems
- Gas Chromatograph
- Gas Quality Analyzer
- Density meters





## METERING BU – EXAMPLES OF APPLICATIONS (GAS)



### **GREEN STREAM – (Italy)**

**N°3 meter runs DN  
20" ANSI 600 –Std.  
ISO 5167 –Straight  
pipe 50xDN**



### **FORAIN Gas Measuring System – (Iraq)**

**N° 2 UFM DN 14" –  
F.C. – Supervisory  
System**



### **SCOGAT (Tunisia)**

**N°5 Systems for fuel-  
gas Compressor  
stations  
(Cap Bon -Feriana-  
Sbikha-Sbeitla-Korba)**





# METERING BU – MEASUREMENT PLANT WITH FISCAL VALUE

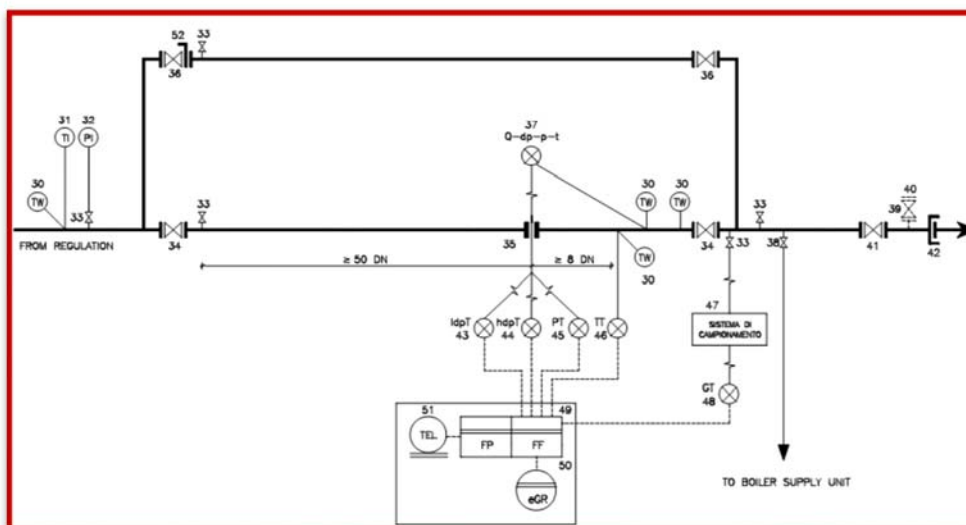
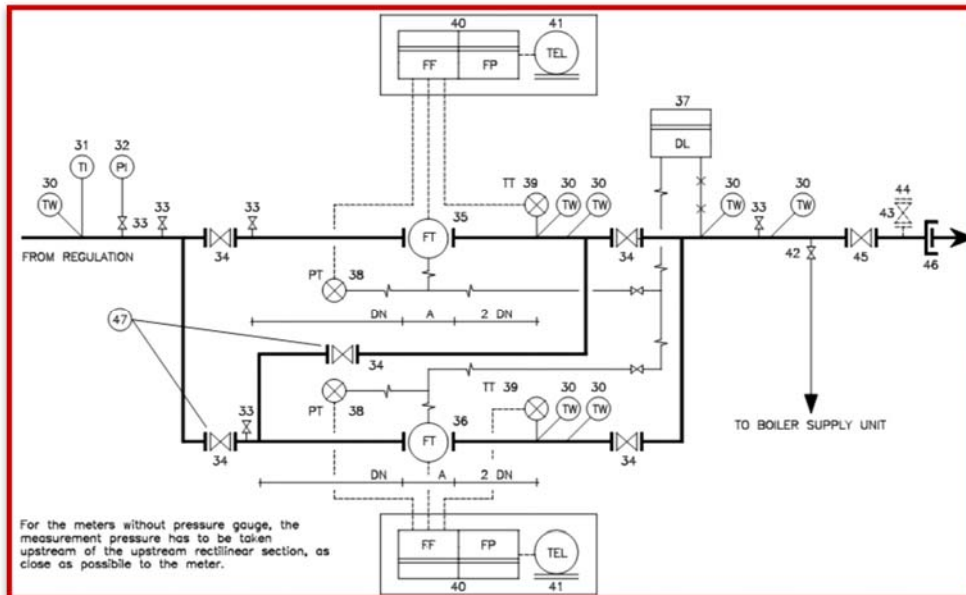
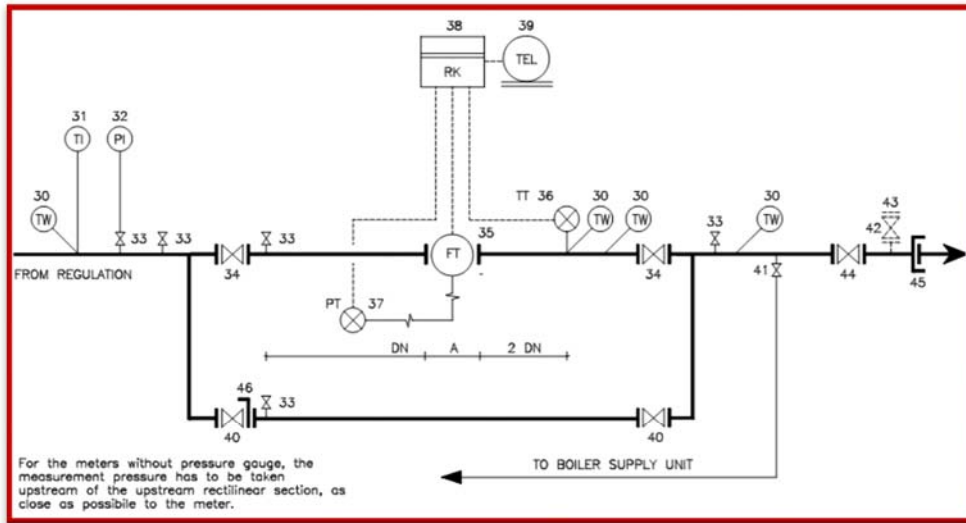





## SKID MOUNTED METERING SYSTEM

During the last 20 years of activities, Socrate SpA has successfully Engineered, Procured, Installed, Commissioned and Revamped the following products and plants:

- Skid mounted Metering Systems.
- Unidirectional and bidirectional Pipe Provers.
- Product Quality Skids (e.g. analyzers, automatic sampling systems).
- Control Systems with dedicated flow computers.
- Sheltered Control Rooms.

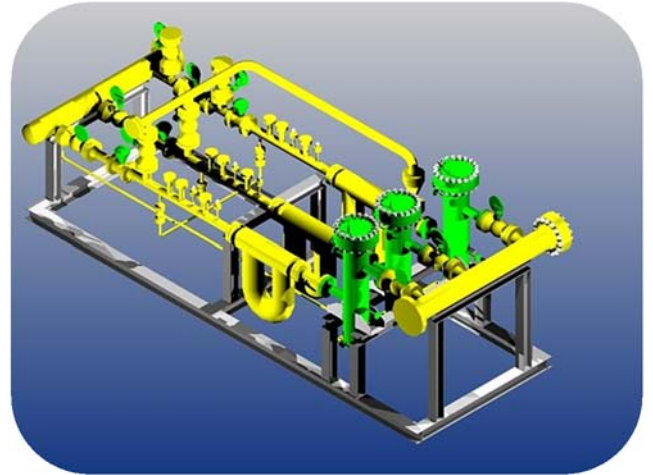

SOCRATE SpA is fully qualified to play a role of EPCC Contractor, in every step of the process.

SOCRATE SpA is able to supply turnkey metering systems applying various technologies, (e.g. turbine, ultrasonic, coriolis, pd meters, orifice fitting), designed

and developed in fully accordance with the most recent and used international standards (AGA, API, ISO etc)

From design to final start-up Socrate SPA personnel is committed to fully satisfy the Client specification in terms of time and quality.

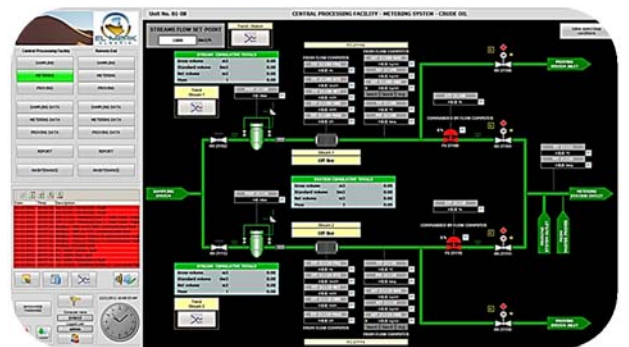



## PROVER AND QUALITY SYSTEMS

**SOCRATE SpA** is specialized in designing, manufacturing, installing and calibrating pipe provers, following the requirements set forth in the most recent API MPMS 4 revisions.

High level of mechanical construction and integration is guaranteed, from material selection and pipe dimensional control to precise workshop calibration, passing through

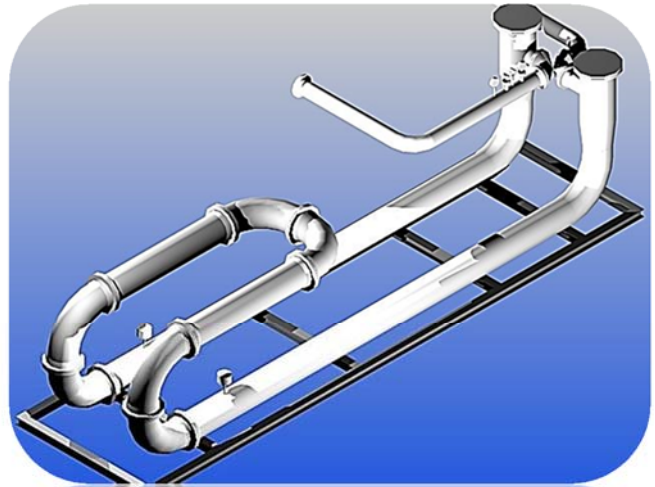

an accurate pipe internal coating and assembling.

Our engineers have broad experience in controlling all the steps of fabrication ensuring total quality of the manufacturing.

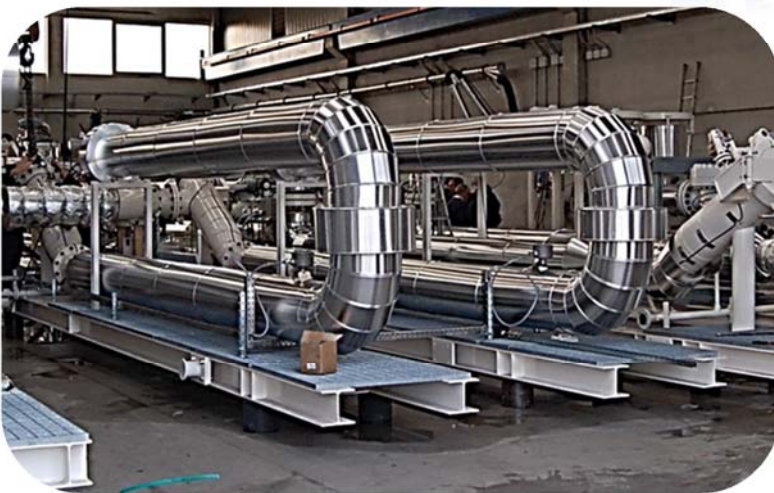

Metering systems often requires additional packages for controlling and measuring the quality of the products (e.g. density, sulfur content, viscosity). Socrate SpA successfully designed and installed quality skids like:

- Automatic sampling systems
- Densitometers and on line analyzers in fast loop





**SOCRATE S.p.A.**

**Via Papa Giovanni XXIII, 5  
20090 Rodano (MI) ITALY**

Tel.: +39 02 95321142

Fax: +39 02 95328094

<http://www.socrate.it>

[sale@socrate.it](mailto:sale@socrate.it)