

N 630 SERIES EXPLOSION PROOF PUMPS



N 630 ST.9 E Ex

ADVANTAGES

- High chemical resistance
- Durable even with difficult operating conditions
- High gas tightness up to 5×10^{-5} mbar x l/s as a standard
- Flameproof motor with intrinsically safe terminal box for simple installation
- .12 version with additional safety diaphragm for preventing gas from escaping through cracks in the working diaphragm

POSSIBLE AREAS OF USE

- Environmental monitoring – especially in potentially explosive fields
- Process industry
- Chemical industry
- Energy technology
- Maritime – especially for engine monitoring and emission measurement

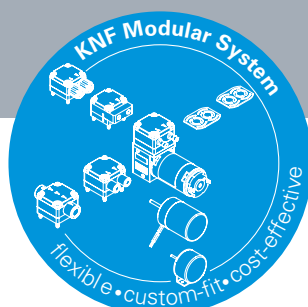

Please visit our website
www.knf.com
to get more information

PERFORMANCE DATA

Series model	N 630 - 50 Hz Version		N 630 - 60 Hz Version	
	ST.9 E Ex	ST.12 E Ex	ST.9 E Ex	ST.12 E Ex
Pump head	Stainless steel			
Diaphragm	PTFE-coated			
Valves	Stainless steel			
Flow rate at atm. pressure (l/min)	30.0		35.0	
Ultimate vacuum (mbar abs.)	120			
Max. operating pressure (bar rel./psig)	4.0/58.0	3.0/43.5	4.0/58.0	3.0/43.5
Permissible ambient temperature (°C)	+5 ... +40			
Permissible media temperature (°C)	+5 ... +40			
Gas tightness (mbar x l/s)	6×10^{-3}	5×10^{-5}	6×10^{-3}	5×10^{-5}
Weight (kg/lbs)	39.5/87.0	41.5/91.5	39.5/87.0	41.5/91.5

ELECTRICAL DATA

Voltage (V)	230/400	200/346	220/380	277/480
Motor	Three-phase motor			
Protection class motor	IP 55			
Protection class pump	IP 20			
Frequency (Hz)	50	50/60	60	
Power P ₂ (W)	370			
Explosion protection three-phase motor	Ex II 2G Ex de IIC T4 Gb			
I _N (A), 50 Hz	1.65/0.95	1.92/1.11	-	
I _N (A), 60 Hz	-	1.8/1.04	1.73/1.0	1.44/0.83
Explosion protection pump parts	Ex II 2G Ex h IIB+H2 T3 Gb			

N 630 ST.9 E EX

PERFORMANCE DATA

Series model	Flow rate at atm. pressure (l/min)	Max. operating pressure (bar rel./psig)	Ultimate vacuum (mbar abs.)
N 630 ST.9 E Ex - 50 Hz	30.0	4.0/58.0	120
N 630 ST.9 E Ex - 60 Hz	35.0	4.0/58.0	120

Flow rate determined at 20 °C, 1013 mbar abs.
(Pressure 0 to 1013 mbar abs. in accordance with ISO 21360-1/2)

N 630 ST.9 E EX

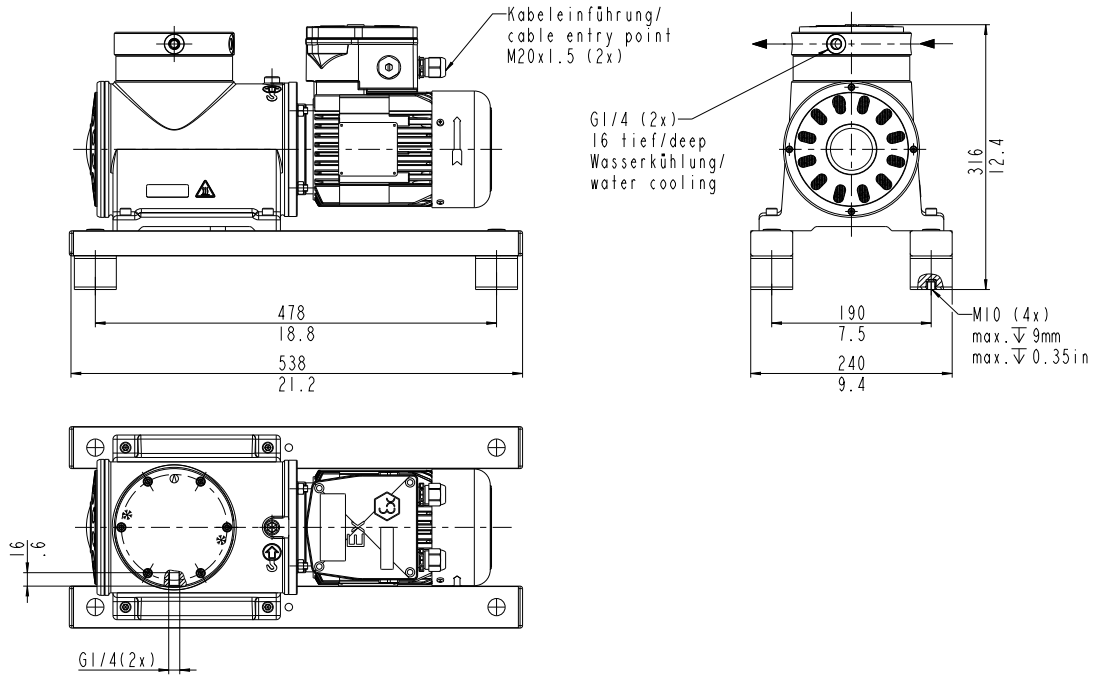

N 630 ST.9 E EX

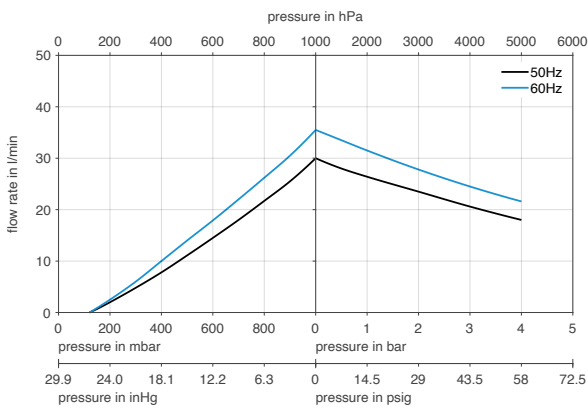

N 630 ST.9 E EX | PUMP UP TIME FOR 20 LITER VESSEL

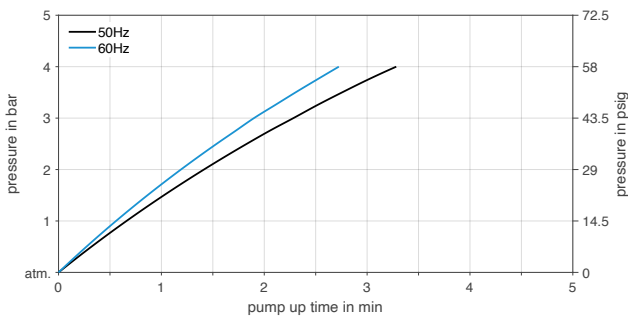

N 630 ST.9 E EX | PUMP DOWN TIME FOR 20 LITER VESSEL

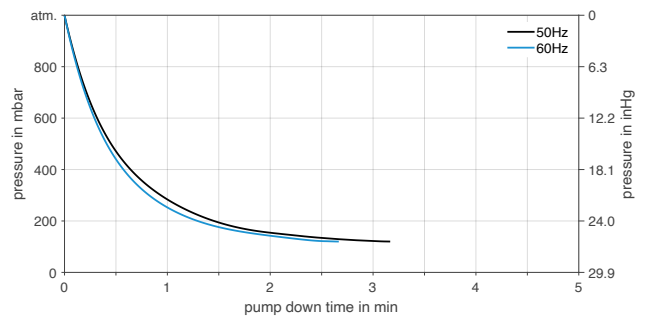

N 630 ST.12 E EX

PERFORMANCE DATA

Series model	Flow rate at atm. pressure (l/min)	Max. operating pressure (bar rel./psig)	Ultimate vacuum (mbar abs.)
N 630 ST.12 E Ex - 50 Hz	30.0	3.0/43.5	120
N 630 ST.12 E Ex - 60 Hz	35.0	3.0/43.5	120

Flow rate determined at 20 °C, 1013 mbar abs.
 (Pressure 0 to 1013 mbar abs. in accordance with ISO 21360-1/2)

N 630 ST.12 E EX

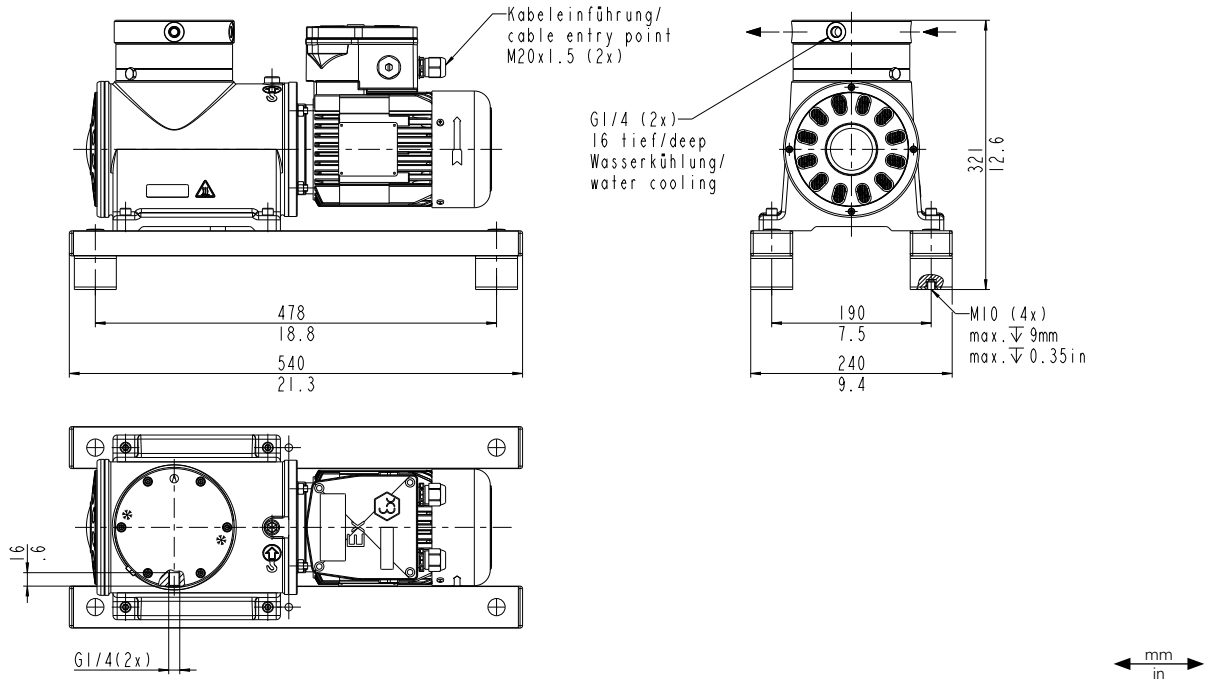

N 630 ST.12 E EX

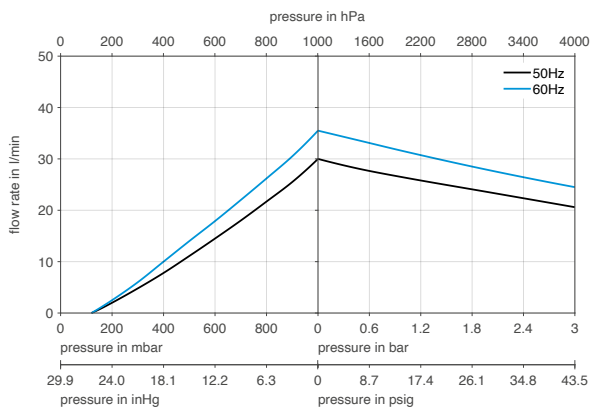



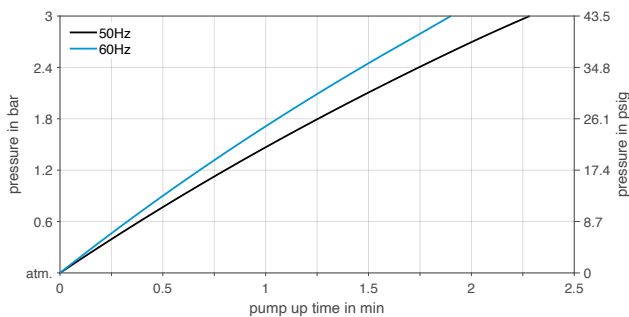

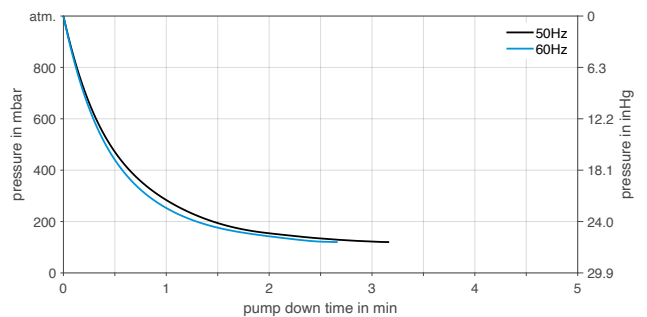

N 630 ST.12 E EX | PUMP UP TIME FOR 20 LITER VESSEL



N 630 ST.12 E EX | PUMP DOWN TIME FOR 20 LITER VESSEL



ACCESSORIES

Description	Illustration	Part No.
Connection water cooling device N 630 ST.9 E Ex ST.12 E Ex		310064
Inlet filter		316661
Wrench for retainer plate		321664
Retainer plate screw N 630 ST.9 E Ex		314279
Retainer plate screw N 630 ST.12 E Ex		314280
Sprocket for coupling		322095
Test adapter for coupling		322184

SPARE PARTS

Description	Part No.
Spare parts kit N 630 ST.9 E Ex	321887
Spare parts kit N 630 ST.12 E Ex	325528

The performance values for the series models shown on this data sheet were determined under test conditions. The actual performance values may differ and depend in particular on the usage conditions and therefore on the specific application, on the parameters of the components involved in the user's system and on any technical modifications carried out which deviate from the standard configuration or the as delivered condition.

If individual designs have been created for specific customers on the basis of series models, other technical performance data may apply. Before operation begins, the relevant operating instructions and/or assembly or installation instructions should be read and the safety information contained in these instructions should be noted. KNF reserves the right to make changes to the product and the associated documentation without prior notice to the customer.



www.knf.com